

# Cummins Diesel

# H-6-IF

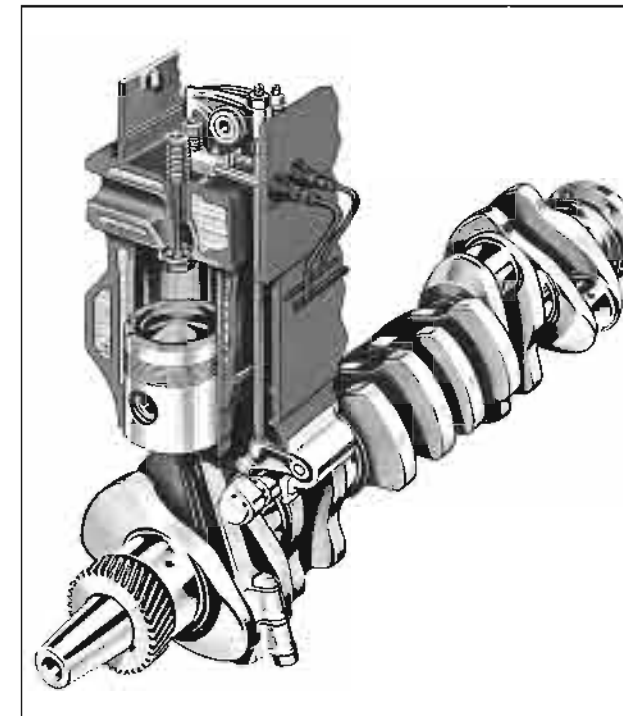
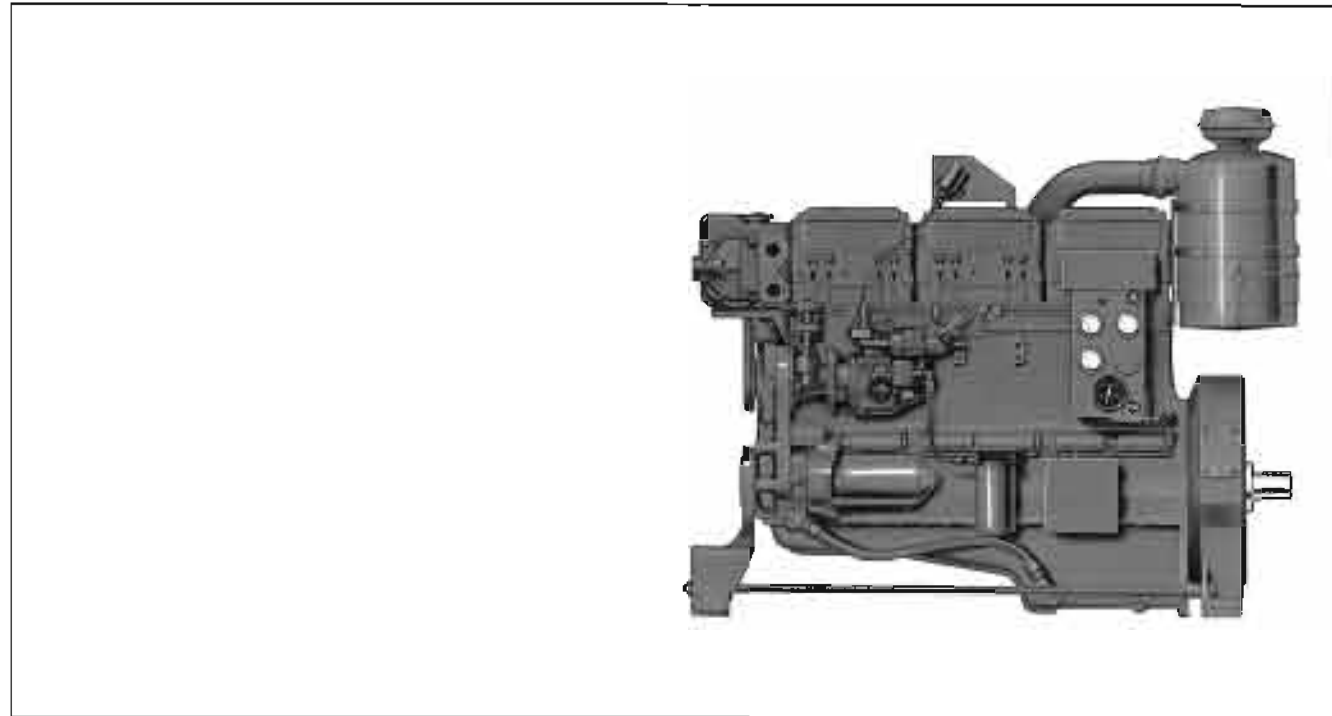

Engines for fire pump service should only be applied at the listed ratings of any one of the following: Underwriters' Laboratories, Inc.; Factory Mutual Fire Insurance Companies; Underwriters' Laboratories of Canada. These ratings are as follows:

**Underwriters' Laboratories Rating:**  
135 HP @ 1750 RPM

**Factory Mutual Ratings:**  
137 HP @ 1750 RPM  
139 HP @ 1800 RPM

**Underwriters' Laboratories of Canada Rating:**  
135 HP @ 1750 RPM

## Specifications

Number of Cylinders ..... 6  
Bore and Stroke ..... 4<sup>7</sup>/<sub>8</sub>" x 6"  
Piston Displacement—cu. in. .... 672  
Operating Cycles ..... 4  
Crankcase Oil Capacity—gals. .... 7  
Engine Coolant Capacity—gals. .... 5  
Net Weight with Standard Accessories (lbs.) . 2500  
Specific ratings are shown on rear page.

## Design Features

**Bearings:** Precision type, steel backed inserts. 7 main bearings, 4<sup>1</sup>/<sub>2</sub>" diameter. Connecting Rod — 3<sup>1</sup>/<sub>8</sub>" diameter.

**Breather, Crankcase:** Dry type element.

**Camshaft:** Single camshaft controls all valve and injector movement. Induction hardened alloy steel with gear drive.

**Camshaft Followers:** Roller type for long cam and follower life.

**Connecting Rods:** Drop forged, 12" center to center length. Rifle drilled for pressure lubrication of piston pin.

**Crankshaft:** High tensile strength steel forging. Bearing journals are induction hardened.

**Cylinder Block:** Alloy cast iron with removable, wet liners.

**Cylinder Heads:** Each head serves two cylinders. Inserts on exhaust valve seats are corrosion resistant.

**Fuel System:** Cummins PT wear-compensating system with integral, flyball type, mechanical variable speed governor. Camshaft actuated injectors.

**Gear Train:** Heavy duty, located at front of cylinder block.

**Lubrication:** Force feed to all bearings, gear type pump. All lubrication lines are drilled passages, except pan to pump suction line.

**Pistons:** Cast Iron, cam ground, with 3 compression and one oil ring.

**Piston Pins:** 2" diameter, full floating.

**Thermostat:** Single unit, modulating by-pass type.

**Valves:** Single intake and exhaust each cylinder. Each valve 1<sup>5</sup>/<sub>8</sub>" diameter. Heat and corrosion resistant face on exhaust valves.

## Big Displacement Design Features

- 1 Large Intake and Exhaust Passages:** Minimize restriction of air and exhaust flow. Allows maximum air charge for clean burning, top economy.
- 2 Overhead Valves:** Precision machined from high strength alloy steel. Intake valves are of silichrome steel. Exhaust valves of big displacement models are nitrogen steel for high temperature strength and faced with corrosion resistant material.
- 3 Open Type Combustion Chamber:** Gives most efficient combustion . . . most power from each gallon of fuel.
- 4 Replaceable Wet-type Cylinder Liners:** Dissipate heat faster. Liners are easily replaced without reboring block.
- 5 Conventional Push Rod and Rocker Lever Arrangement:** Activates valves and injectors from a single camshaft. Roller type camshaft followers are used for long life.
- 6 Cam-ground Pistons:** Assure perfect fit at operating temperatures.
- 7 Alloy Cast Iron Cylinder Block:** Follows proven design and material specification to achieve maximum durability.
- 8 Large Volume Water Passages:** Give even flow of coolant around cylinder liners, valves and injectors to draw excess heat from combustion chamber. Centrifugal pump circulates large volumes of water.
- 9 Connecting Rods:** Forged from high tensile strength alloy steel. I-beam section gives maximum strength. Large diameter piston pins are full-floating.
- 10 Crankshafts:** Precision machined from high tensile strength steel forgings. Bearing journals are induction hardened for long life.

## Performance

The horsepower ratings listed above represent performance at sea level altitude (29.92 inches of mercury) and 60°F. intake air temperature. Ratings represent performance of the engine with all standardly fitted parasitic losses deducted, including fuel system, lubricating oil pump, water pump, air cleaner and battery charging generator.

Curves represent performance on No. 2 diesel or furnace oil. Equivalent results can be obtained with fuels ranging from heavy furnace oils to light jet and military type fuels without recalibration. The net horsepower ratings are to be derated 5% for each 1000 feet above sea level, in accordance with National Board of Fire Underwriters Standard No. 20.



Listed under Underwriters' Laboratories, Inc., reexamination service for fire protection applications.



Listed by Associated Factory Mutual Fire Insurance Companies for fire protection applications.



Listed under Underwriters' Laboratories of Canada reexamination service for fire protection applications.

Cummins Engine Company, Inc., Columbus, Indiana 47201  
Cummins Americas, Inc., Columbus, Indiana, U.S.A.  
Cummins Diesel Australia, Ringwood, Australia  
Cummins Diesel International Ltd.  
Cummins Engine Company Ltd., London, England

# MODEL H-6-IF CUMMINS DIESEL

## FIRE PUMP ENGINE



Listed under Underwriters' Laboratories, Inc., reexamination service for fire protection applications.



Listed by Associated Factory Mutual Fire Insurance Companies for fire protection applications.

Bore and Stroke	4 $\frac{7}{8}$ " x 6"
Number of Cylinders	6
Piston Displacement (cu. in.)	672
Horsepower	See Curve
Crankcase Oil Capacity (gals.)	5
Cooling System Capacity (gals. engine only.)	5
Air flow — cfm	275
Net Weight with Standard Accessories (lbs.)	2500

### BEARINGS:

**Camshaft:** 7 bearings, 2" diameter.

**Crank Pin:** 3 $\frac{1}{8}$ " diameter x 2 $\frac{3}{8}$ " length. Removable precision type shells. Projected area 6.18 sq. in.

**Main:** 7 bearings, 4 $\frac{1}{2}$ " diameter. Removable shell held in place by "I" beam section caps. Projected area 61.15 sq. in.

**Piston Pin:** 3 bearings, 2 in piston and 1 in rod, 2" diameter.

**BREATHER, Crankcase:** Dry type element.

**CLEANER, Air:** Oil bath type (mounted).

**CRANKSHAFT:** High tensile strength steel forging. All bearing journals induction hardened.

**CYLINDERS:** Cast enbloc, with removable wet liners.

**ELECTRICAL EQUIPMENT:** 24-volt system: 24-volt starting motor; 20 ampere generator; voltage regulator; toggle starting switch.

**EXCHANGER, Heat:** Tubular type.

### FILTERS:

Fuel Oil (mounted).  
Lubricating Oil, full flow, (mounted).

**FLYWHEEL:** Machined to fit drive flange.

**GOVERNOR:** Mechanical variable speed type.

**HEADS, Cylinder:** Cast in pairs. Stellite inserts on exhaust valve seats.

**HOURLMETER:** Electrical type.

**HOUSING, Flywheel:** S.A.E. No. 1 with pedestal mounting supports.

**INJECTORS:** Exclusive Cummins cam actuated PT metering type.

**LUBRICATION:** Full pressure to all bearings. Gear type pump.

**MANIFOLD, Air:** Connected to air cleaner.

**MANIFOLD, Exhaust:** Water-cooled.

**PAN, Oil:** Rear sump type.

**PANEL, Instrument:** With ammeter, lubricating oil pressure gauge, lubricating oil temperature gauge, water temperature gauge, throttle control, toggle starting switch.

**PISTONS:** Cam ground.

### PUMPS:

Fuel—Exclusive Cummins PT pump.  
Lubricating Oil—Gear type, located on outside of engine gear case housing.  
Water—Circulating, centrifugal type, driven by 1 V-belt, 85 gpm at 1800 rpm.

**RINGS, Piston:** 3 compression rings, <sup>2</sup>/<sub>1</sub> oil ring.

**RODS, Connecting:** Drop-forged, 12" center to center. Rifle drilled for pressure lubrication to piston pin.

**ROTATION, Engine:** Clockwise when viewed at timing gear end.

**SUPPORTS, Engine:** Pedestal type.

**THERMOSTAT:** Single unit type.

**THROTTLE, Hand Control:** On panel.

**VALVES, Intake and Exhaust:** Heat-resisting alloy steel. Diameter, 1 15/16".

CEX 157  
VOL 2  
FIG 13

*Remade*

# CUMMINS FIRE PUMP ENGINE PERFORMANCE

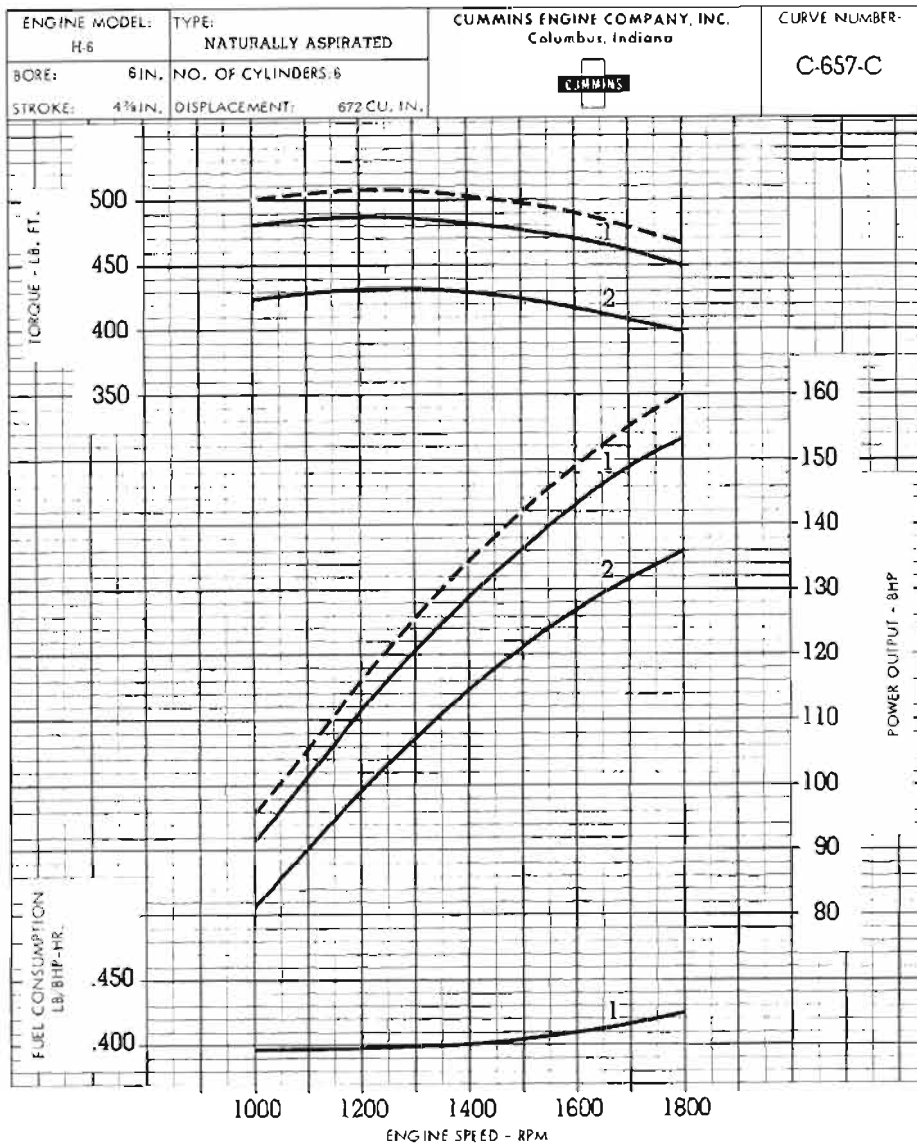

For fire pump applications, the engines are to be applied on the No. 2 performance curve. This is the net torque and horsepower available for fire pump service with all auxiliary equipment connected. The engines are capable of operating on the dotted curve at sea level, 60° F. conditions, which is 15% above the stated net ratings.

The net horsepower ratings are to be derated 5% for each 1000 ft. above sea level, in accordance with National Board of Fire Underwriters Standard No. 20.

Refer to the listing of either Factory Mutual or Underwriters Laboratories for determination of the specific approved rating points.

REVIEWED BY ENGINEERING DEPT.  
ISSUED BY LABEL SERVICE DEPT.  
NOV 8 1968  
UNDERWRITERS' LABORATORIES  
OF CANADA

**CUMMINS ENGINE COMPANY, INC., COLUMBUS, INDIANA**



## Standard Equipment

Breather, Crankcase: Dry type element.

Cleaner, Air: 10" diameter, oil bath type, mounted.

Cooler, Lubricating Oil: Tubular type, jacket water cooled.

Damper, Vibration: Viscous type.

Electrical Equipment: 24 volt positive ground system. 24 volt starting motor; 24 volt, 20 ampere generator; voltage regulator; toggle switch and magnetic switch.

Exchanger, Heat: Tubular type, mounted.

Filters: Fleetguard. Lubricating oil, full flow replaceable paper element, mounted. Fuel, paper element replaceable type, mounted.

Flywheel: Machined to fit drive flange.

Governor: Mechanical flyball, mechanical variable speed type.

Housing, Flywheel: SAE No. 1 with industrial supports.

Manifold, Air Intake: With common inlet, connected to air cleaner.

Manifold, Exhaust: Water cooled with center outlet directed upwards.

Pan, Oil: Cast aluminum, rear sump type, 7 U.S. gallon capacity.

Panel, Instrument: Mounted. Includes ammeter, combination tachometer and hourmeter, water temperature gauge, lubricating oil pressure gauge, vernier type throttle control.

Pump, Coolant: Belt driven, centrifugal type.

Stubshaft: Mounted to drive flange on flywheel.

Support, Engine: Pedestal type, front and rear.

Tank, Fuel Scavenge: Mounted.

Transfer Pump, Fuel: Mounted.

