



## Specification Sheet

# Commercial Mobile Generator

## ONAN QD 6000/7500/8000



### Features and Benefits

- Load-matching, variable speed operation
- Unique sound-controlled housing encloses cooling system and muffler - simplifies installation
- Three-point, fully focalized internal mounting system reduces vibration
- Dramatically lower noise, vibration, harshness (NVH)
- Up to 15 dB(A) quieter than conventional diesel generator sets
- Enclosed muffler for added quietness, easy installation
- Self-diagnostic capabilities simplify troubleshooting
- Pure sine wave output for high quality power
- Convenient, top-mounted switches and coolant level check/fills
- Service and maintenance points accessible through easy-latch side service door
- Automatic glow plug eliminates preheat time uncertainty
- Complete, integrated package for easy, low-cost installation

### Weight, Size and Sound Level

<b>Weight</b>	420 lbs	(191 kg)
<b>Length</b>	36.4 in	(923 mm)
<b>Width</b>	24.2 in	(615 mm)
<b>Height</b>	22.3 in	(566 mm)
<b>Sound</b>	50/63/63 dB(A)	Readings at 10 ft (3 m), before installation, half load

- Typical installation will further reduce sound level.

### Models and Ratings

Model	Fan	Hz	Watts	Voltage	Amps	PF	Phase	Circuit breaker
<b>6 HDKAV-41934</b>	Internal	60	6000	120	50	1.0	1	(1) 2 Pole, 30 A
<b>7.5 HDKAT-41934</b>	Internal	60	7500	120	62.5	1.0	1	(1) 2 Pole, 35 A
<b>8 HDKAU-41934</b>	Internal	60	8000	120	66.6	1.0	1	(2) 2 Pole, 35 A

- All 60 Hz models operate at 1800 r/min
- Ratings apply up to 500 ft (152 m) altitude, 85° F (29.4° C) ambient\* with No. 2 diesel fuel.
- Temperature: Power output decreases 1% for every 10° F (5.5° C) increase
- Altitude: Power output decreases 3.5% for every 1000 ft (305 m) increase
- Ratings are at intermittent power output.
- Continuous rating is 85% of intermittent output.

\*Ambient is defined as the air temperature measured at the cooling air inlet to the set

## Standard Features

- 3 cylinder diesel engine
- Permanente magnet alternator
- Pure sine wave output
- Digital voltage regulation with no adjustments required
- Bottom air inlet and outlet configuration
- Integral enclosed muffler with stationary exhaust pipe connection point
- USDA approved spark arresting muffler
- Internal radiator
- Sound attenuated housing (Sound insulated cover with cooling air inlet and outlet ducts)
- Intake silencer
- Heavy duty air cleaner
- Maintenance free electronic governor
- Fused DC circuits
- Automotive type starter
- Regulated-voltage 10 A battery charging
- Hour meter
- Waterproof connector for remote operation
- Focalized mounting system with 3-point vibration isolation
- Over voltage, low oil pressure, over temp, over speed, and overload safeties
- Bulkhead type connections for fuel and battery
- Terminal block connection for AC output
- Electric fuel pump, long-life fuel filter
- Spin-on, full-flow oil filter
- Service and maintenance from below or side service access panel
- Automatic timed glow plugs for quick easy start
- Instant one touch stop
- Water resistant controls

## Engine Details

**Model:** Kubota 722

**Design:** 4-cycle, liquid-cooled diesel engine

**Cylinders:** 3, inline vertical

**Bore:** 2.64 in (67 mm)

**Stroke:** 2.68 in (68 mm)

**Displacement:** 43.88 in<sup>3</sup> (719 cm<sup>3</sup>)

**Compression Ratio:** 23:1

**Lube Oil Capacity:** 2.8 qt (2.6 L)

**Cooling System Capacity:** 4 qt (4.2 L)

**Power (max):** At 3600 r/min 16.6 hp (12.4 kW) EPA Tier 4F non-road

**Starting System:** Remote, 12 V

**Combustion Chamber:** Spherical (TVCS)

## Average Fuel Consumption

No. 2 Diesel Fuel	No load	Half load	Full load
<b>6.0 HDKAV</b>	0.21 Gal/h (0.8 L/h)	0.40 Gal/h (1.5 L/h)	0.70 Gal/h (2.6 L/h)
<b>7.5 HDKAT</b>	0.21 Gal/h (0.8 L/h)	0.56 Gal/h (2.1 L/h)	0.96 Gal/h (3.6 L/h)
<b>8.0 HDKAU</b>	0.21 Gal/h (0.8 L/h)	0.61 Gal/h (2.3 L/h)	1.02 Gal/h (3.9 L/h)

## Alternator Details

**Design:** Cummins, permanent magnet

**Insulation System:** Class H per NEMA MG1-1.66

**Exciter System:** None

**Bearings:** None

**Cooling:** Direct drive centrifugal blower

## Generator Set Performance

### Control:

- Microprocessor control
- Integrated generator set and engine control
- User and service personnel accessible diagnostics
- Fused DC circuits
- Over voltage safety
- 'Hour meter
- Water resistant control switches
- Low oil pressure safety
- Overload safety
- Automatically times glow plugs
- On- touch stop

<b>Frequency regulation</b>	No load/Full load	0.1%	<b>Frequency regulation</b>	Constant load	0.5%
<b>Voltage regulation</b>	No load/Full load	1%	<b>Voltage regulation</b>	Constant load	2%

## Basic Dimensions

Dimensions in (mm)

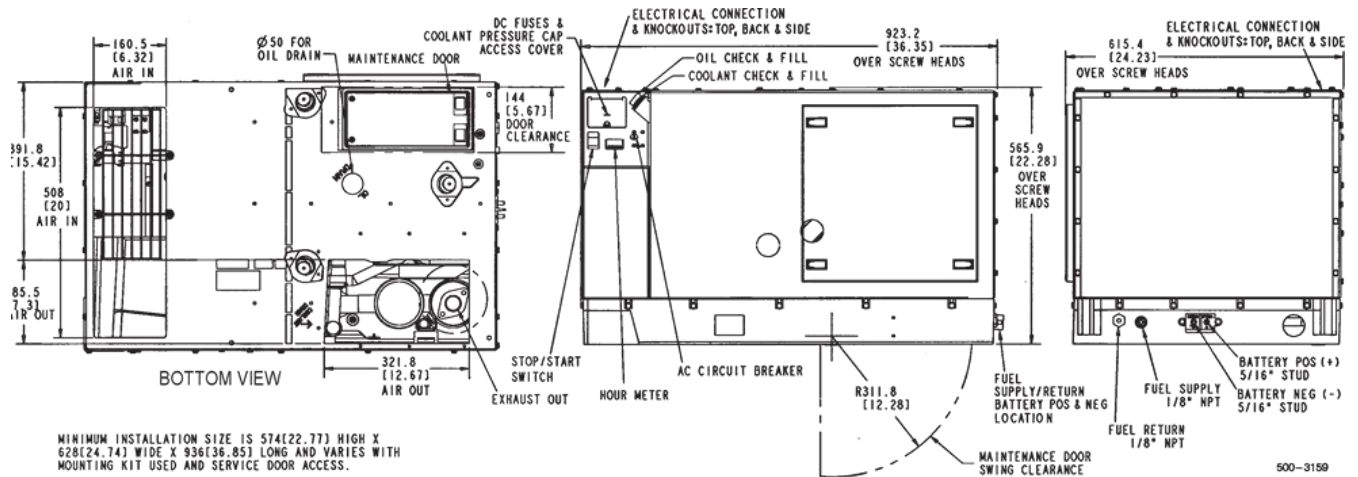

**Note:** This outline drawing is provided for general reference only and is not intended for design or installation. For more information see Operation and Installation manuals or obtain drawing 500-3159 and wiring diagram from your distributor/dealer.

## Accessories

- Remote air cleaner kit (P/N 541-0531)
- Auxiliary fuel pump kit (P/N 541-0530)
- Remote control panel, switch only (P/N 300-4942)
- Remote control panel, switch and hour meter (P/N 300-4943)
- Remote control panel, switch and DC voltmeter (P/N 300-4944)
- Remote gauge panel, switch, DC voltmeter, water temperature gauge, oil pressure switch and hour meter (P/N 300-5218 Spec A, P/N 300-5027 Spec B and later)
- Remote harness (for use with remote panels), 10 ft (P/N 338-3490-01), 30 ft P/N 338-3490-02)
- Remote control harness pigtail (P/N 300-4947)
- Remote harness pigtail at panel (P/N 338-3573)
- Exhaust adapter, 7 in (P/N 155-2424), 3 in (P/N 155-2610)
- Exhaust elbow, 90° (P/N 155-2982)

## Testing for RV Application

- Tested at extremes of temperature -20 °F (-29 °C) to 120 °F (49 °C) for starting and operation
- Tested with commercial loads
- Tested in high humidity conditions
- Tested in salt spray conditions – no direct spray allowed
- Tested in heavy airborne dust conditions
- Field test program
- This product meets U.S. EPA Tier IV
- This generator set was designed and manufactured in facilities certified to ISO 9001
- CSA certified for CSA C22.2 std 100 and std 14



## Warranty Policy

The limited warranty covers any failures of the product resulting from a defect in material or factory workmanship under normal use and service for 2 years from warranty start date or 2,000 hours, whichever occurs first. Parts and labor will be covered for warrantable failures except routine maintenance during two years warranty coverage period.

## After Sale Support

### Largest Distributor/Dealer Support Network:

Cummins generator sets are supported by the largest and best trained worldwide authorized distributor/dealer network in the industry. This network of knowledgeable Cummins distributor/dealers will help you select and install the right generator set and accessories to meet the requirements of your specific application. This same network offers a complete selection of commonly used generator set maintenance parts, accessories and products plus manuals and specification sheets. They can answer your questions regarding proper operation, maintenance schedules and more.

**Manuals:** Operation and installation manuals ship with the generator set. To obtain additional copies or other manuals for this model, see your Cummins sales or service representatives and request the following manual numbers: Operator (981-0161), Installation (981-0623), Parts (981-0200), Service (981-0522).

To easily locate the nearest Cummins distributor/dealer in your area, or for more information, contact us at 1-800-CUMMINS, or [www.power.cummins.com](http://www.power.cummins.com)

<b>!</b>	<b>WARNING:</b>
Do not use this generator set on a boat. Such use may violate U.S. Coast Guard regulations, and can result in severe personal injury or death from fire, explosion, electrocution, or carbon monoxide poisoning.	

<b>!</b>	<b>WARNING:</b>
Back feed to a utility system can cause electrocution and/or property damage. Do not connect to any building electrical except through an approved device or after building main breaker is open.	

Contact your distributor/dealer for more information.



Cummins Inc.  
Box 3005  
Columbus, IN 47202-3005  
U.S.A  
1-800-CUMMINS™ (1-800-286-6467)  
[cummins.com](http://cummins.com)

©2020 Cummins Inc. All rights reserved.  
Specifications are subject to change without notice. A-1486 (04/20)