

QSX15 XPI ENGINE AND COOLPAC

OPTIMAL
PERFORMANCE
THAT'S ALWAYS ON.



POWERED
BY
Cummins
G-DRIVE

INDUSTRY-LEADING XPI FUEL SYSTEM TECHNOLOGY FROM CUMMINS

CUMMINS HIGHLY-REGARDED SIGNATURE QSX15 ENGINE DELIVERS:

- **Excellent transient response** – built with Cummins wastegated Turbocharger for optimal operation across the torque curve with improved response
- **Enhanced fuel efficiency** – precise quantity of fuel supply at ultrahigh pressures and robust electronic engine control integration enables multiple injection events per cycle
- **Reduced service intervals** – specially designed fuel and lube filters protect the engine and minimise downtime
- **Ultra-dependable service and support** – G-Drive products backed by an uncompromising level of technical support and after sales service from a world class service network
- **Coolpac integrated design*** – select QSX15 products are supplied with cooling package and air cleaner kit for a complete power package. Each component has been specifically engineered and rigorously tested for superior system performance, durability and reliability.

*QSX15 G8 and G9

QSX15-G4, 1500rpm

Standby: 450kVA

Prime: 400kVA

QSX15-G4, 1800rpm

Standby: 400kWe

Prime: 360kWe

QSX15-G6, 1500rpm

Standby: 500kVA

Prime: 450kVA

QSX15-G6, 1800rpm

Standby: 400kWe

Prime: 360kWe

QSX15-G7, 1800rpm

Standby: 450kWe

Prime: 400kWe

QSX15-G8, 1500rpm*

Standby: 550kVA

Prime: 500kVA

QSX15-G8, 1800rpm*

Standby: 400kWe

Prime: 360kWe

QSX15-G9, 1800rpm*

Standby: 500kWe

Prime: 450kWe

*Coolpac available

FLEETGUARD SPIN-ON FUEL FILTRATION SYSTEM

Fleetguard 2-stage fuel filters block impurities down to seven microns, providing superior protection against dust, dirt or water contamination.

FULL AUTHORITY ELECTRONIC DUAL SPEED ENGINE

Advanced engine monitoring, diagnostics, protection and control features.

15L, IN-LINE, SIX CYLINDER, TURBOCHARGED, CHARGE AIR COOLED

NORMAL DUTY AIR CLEANER

HIGH AMBIENT COOLING SYSTEM

Best in class performance, no derate up to 600m at 50°C.

PATENTED SPIN-ON FLEETGUARD LUBE AND BYPASS FILTERS

High performance lube oil filtration providing extended protection for engine components.

CUMMINS EXTREMELY HIGH PRESSURE INJECTION (XPI) FUEL SYSTEM

Improved fuel efficiency, lower noise and enhanced engine performance.

SAE 1 FLYWHEEL TYPE

SAE 0 available for Stanfast only.

DELCO-REMY 39MT-HD 24 VOLT

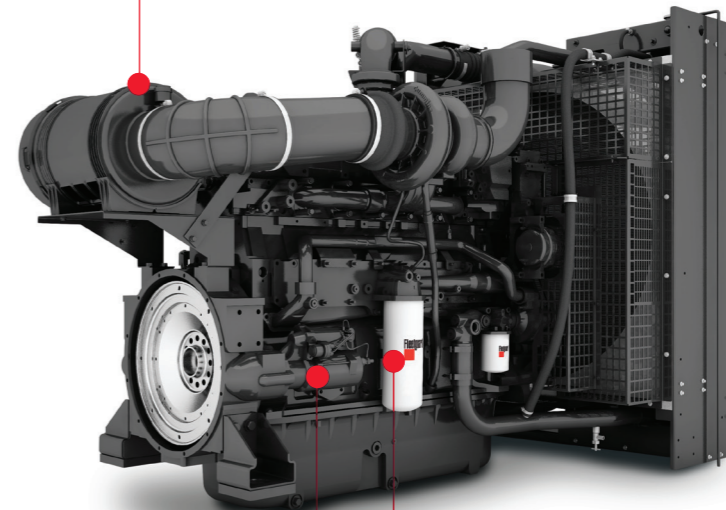
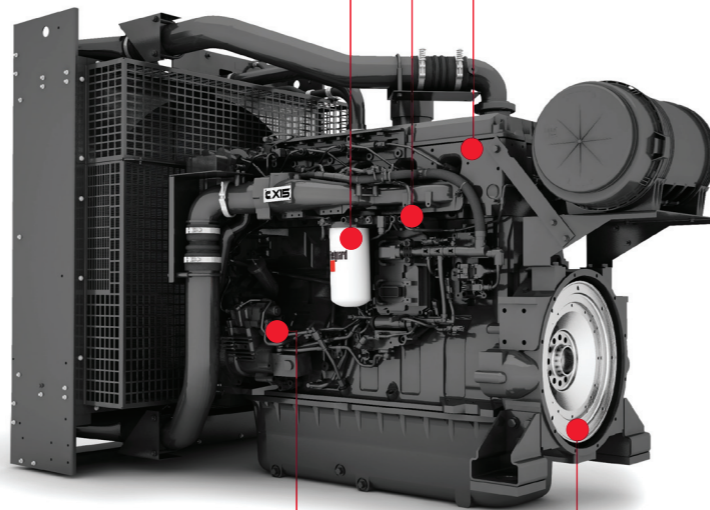

GLOBAL PRESENCE FOR SERVICE AND SUPPORT WHEREVER YOU NEED IT.



**8000
DISTRIBUTOR
AND DEALER
LOCATIONS.**

No matter where in the world you are, your local Cummins distributor or dealer is your first line of support for everything from application assistance and on-site commissioning to troubleshooting, maintenance and aftermarket services.



cummins.com

Bulletin 5600688 Printed in U.K. 9/20
©2020 Cummins Inc.