

# BUILT FOR THE MOST DEMANDING VOCATIONS

SPECIALTY PRODUCTS





## PROVEN PERFORMANCE BUILT FOR THE MOST DEMANDING SPECIALTY VOCATIONS

Construction. Utility. Fire and rescue. Bus and coach. The most demanding vocations require the industry's most proven axles, brakes and components. Our parts are specifically designed for the challenge. As the world's largest independent manufacturer of truck axles for a broad range of vehicle applications, we know how to build axles and specialty components that perform in the toughest conditions, with outstanding reliability, unmatched durability and low cost of operation.

### THE EXPERTS YOU CAN TRUST

With over 100 years of "forward thinking," we have produced unsurpassed leadership in the design, engineering and manufacturing of axles for the transportation industry. Recognized as a global leader across specialty and severe service applications for front and rear axle solutions, we offer a broad range of axles, brakes, drivelines and components.

### EVERYTHING YOU NEED TO STAY AHEAD

Our full line of vocational axles, brakes and drivelines features forward-thinking innovations designed to give you a true competitive edge. And all are backed by industry-leading service and support with comprehensive warranty coverage.

# FRONT AXLES

Our broad range of front non-drive steer axles and front drive steer axles combine unsurpassed steering control, durability and low maintenance to offer one of the industry's most complete front axle portfolios. From the mobility of the MX Series single-reduction front drive steer axle for front discharge mixers to the durability of the MFS Series for fire trucks to the adaptability of the FH non-drive models for bus and coach applications, Meritor® front axles deliver.

- Custom center or offset carrier bowl
- Double cardan steering joints offer up to 42-degree wheel cut capability
- Performance-enhancing steering geometry with easy-to-maintain, robust, adjustable king pins
- High ground clearance for severe-duty mobility in all terrain conditions
- 16.5-inch by 5-inch heavy-duty S-cam extended service air brakes with automatic slack adjusters and air chambers
- 10 stud by 285.75 mm bolt circle, hub piloted wheel mount or optional 10 stud by 335 mm bolt circle
- Anti-lock braking system (ABS) compatible
- SPL140 or SPL100 pinion yoke installed on drive axles
- Customization for specific applications and exceptional OEM packaging flexibility
- Ease of serviceability and low operating costs

Features vary based on model. Contact your sales representative for exact specifications for your application.



## FRONT NON-DRIVE STEER AXLE SPECIFICATIONS

| Ratings*              | Axle model     | Axle beam drop            | King pin intersection | Wheel-end series |
|-----------------------|----------------|---------------------------|-----------------------|------------------|
| 12,000 lbs (5,448 kg) | MFS-12-155     | 6.5 in (165 mm)           | 75.75 in (1,924 mm)   | FF/FG            |
|                       | MFS-12-143A-N  | 3.74 in (95 mm)           | 71.5 in (1,816 mm)    |                  |
|                       | MFS-12-144A-N  | 5 in (127 mm)             |                       |                  |
|                       | FF-941         | 3.5 in (89 mm)            | 69 in (1,753 mm)      |                  |
|                       | FF-943         | 5 in (127 mm)             |                       |                  |
|                       | FF-961         | 3.5 in (89 mm)            |                       |                  |
|                       | FF-966         | 3.5 in/2 in (89 mm/51 mm) |                       |                  |
| FF-967                |                |                           |                       |                  |
| 13,200 lbs (5,993 kg) | FF-942         | 3.5 in (89 mm)            |                       |                  |
|                       | FF-944         | 5 in (127 mm)             |                       |                  |
|                       | MFS-13-155     | 6.5 in (165 mm)           | 75.75 in (1,924 mm)   |                  |
|                       | MFS-13-143A-N  | 3.74 in (95 mm)           | 71.5 in (1,816 mm)    |                  |
|                       | MFS-13-144A-N  | 5 in (127 mm)             |                       |                  |
| 14,600 lbs (6,628 kg) | FG-941         | 3.5 in (89 mm)            | 69 in (1,753 mm)      |                  |
|                       | FG-943         | 5 in (127 mm)             |                       |                  |
| 14,700 lbs (6,674 kg) | MFS-14-143A-N  | 3.74 in (95 mm)           | 71.5 in (1,816 mm)    |                  |
|                       | MFS-14-144A-N  | 5 in (127 mm)             |                       |                  |
| 16,000 lbs (7,264 kg) | MFS-16-143A-N  | 3.74 in (95 mm)           | 69 in (1,753 mm)      |                  |
|                       | MFS-16-122A-N  | 3.5 in (89 mm)            |                       |                  |
| 16,500 lbs (7,500 kg) | FH-941         | 3 in (76 mm)              | 74.5 in (1,892 mm)    |                  |
|                       | FH-946         | 0.94 in (24 mm)           |                       |                  |
| 18,000 lbs (8,165 kg) | MFS-18-133A-N  | 3.74 in (95 mm)           | 71 in (1,803 mm)      | FL               |
| 20,000 lbs (9,080 kg) | FL-941         | 3.5 in (89 mm)            | 68.5 in (1,740 mm)    |                  |
|                       | FL-943         | 5 in (127 mm)             | 68.8 in (1,748 mm)    |                  |
|                       | MFS-20-133A-N* | 3.74 in (95 mm)           | 71 in (1,803 mm)      |                  |

## FRONT DRIVE STEER AXLE SPECIFICATIONS

| Ratings*               | Axle model | Standard ratios  | Ring gear size    | Bowl offset (passenger side)                            | Max. turn angle | King pin intersection  | Wheel-end series |
|------------------------|------------|--|-------------------|---|-----------------|--|------------------|
| 10,000 lbs (4,540 kg)  | MX-10-120  | 4.30, 4.57, 4.88, 5.13, 5.29, 5.57, 5.86, 6.14   | 13.25 in (337 mm) | 10 in (254 mm) standard<br>10.75 in (273 mm) wide track | 42°             | 69 in (1,752 mm) standard<br>70.5 in (1,790 mm) wide track   | MTOR             |
| 12,000 lbs (5,448 kg)  | MX-12-120  |  |                   |   |                 |  |                  |
| 14,000 lbs (6,350 kg)  | MX-14-120  |  |                   |   |                 |  |                  |
| 16,000 lbs (7,258 kg)  | MX-16-120  |  |                   |   |                 |  |                  |
| 17,000 lbs (7,945 kg)  | MX-17-140  | 2.79, 2.93, 3.07, 3.21, 3.42, 3.58, 3.73, 3.90, 4.10, 4.33, 4.63, 4.88, 5.13, 5.29, 5.57, 5.86, 6.14, 6.43, 6.83, 7.17 | 15.31 in (389 mm) | 0   | 35°             | 66.5 in (1,689 mm) standard<br>68.5 in (1,740 mm) wide track |                  |
| 18,000 lbs (8,165 kg)  | MX-18-120  | 4.30, 4.57, 4.88, 5.13, 5.29, 5.57, 5.86, 6.14   | 13.25 in (337 mm) | 10 in (254 mm) standard<br>10.75 in (273 mm) wide track | 42°             | 69 in (1,752 mm) standard<br>70.5 in (1,790 mm) wide track   |                  |
| 19,000 lbs (8,626 kg)  | MX-19-140  | 2.79, 2.93, 3.07, 3.21, 3.42, 3.58, 3.73, 3.90, 4.10, 4.33, 4.63, 4.88, 5.13, 5.29, 5.57, 5.86, 6.14, 6.43, 6.83, 7.17 | 15.31 in (389 mm) | 0   | 35°             | 66.5 in (1,689 mm) standard<br>68.5 in (1,740 mm) wide track |                  |
| 21,000 lbs (9,434 kg)  | MX-21-140  | 3.07, 3.21, 3.42, 3.58, 3.73, 3.91, 4.10, 4.30, 4.56, 4.89, 5.13, 5.29, 5.38, 5.63, 5.86, 6.14, 6.43, 6.83, 7.17       | 18 in (457 mm)    |   |                 |  |                  |
|                        | MX-21-160  |  |                   |   |                 |  |                  |
| 23,000 lbs (10,442 kg) | MX-23-160  | 4.10, 4.56, 4.89, 5.13, 5.29, 5.38, 5.63, 5.86, 6.14, 6.43, 6.83, 7.17   | 11.7 in (297 mm)  | 1.67 bowl, 1 pinion<br>8.4 bowl, 2.6 pinion             | 43°             | 62.5 in (1,588 mm)<br>68.8 in (1,748 mm)                     |                  |
| 25,000 lbs (11,350 kg) | MX-23-810  | 4.88, 5.38, 5.58, 5.63, 5.86, 6.14, 6.85, 7.16, 7.80   |                   |   |                 |  |                  |

\* Refer to publication TP-7824 for complete axle specification details. Higher load ratings may be granted for specific axles based upon application review and customer integration studies/approvals. Contact your sales representative for exact specifications for your application.

# SINGLE REAR AXLES

Our wide range of offerings include hypoid single-reduction and helical-hypoid double-reduction axles, and deliver a unique combination of precision engineering, component durability and lightweight options to meet the demands of diverse customer applications.

## FEATURES AND BENEFITS

- Proven, robust designs combined with high-strength engineered materials for superior performance and proven durability
- Precision-forged differential gears provide high strength and shock resistance
- Wide range of axle configurations and various housing bowl positions provide application customization and exceptional OEM packaging flexibility
- Widest range of gear ratios available to meet specific needs for improved fuel economy, greater torque or maximum traction
- Hypoid-generoid™ gearing options provide long life and durability
- Optional driver-controlled differential lock (DCDL) for enhanced traction and spin out protection in slippery conditions

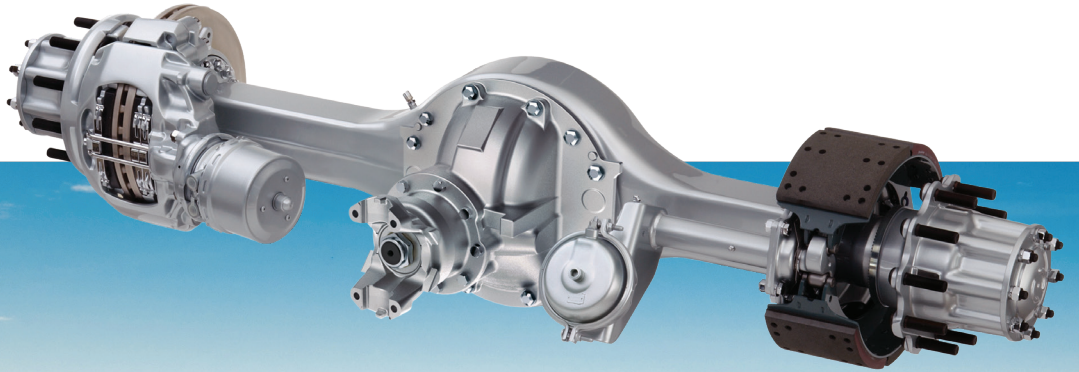

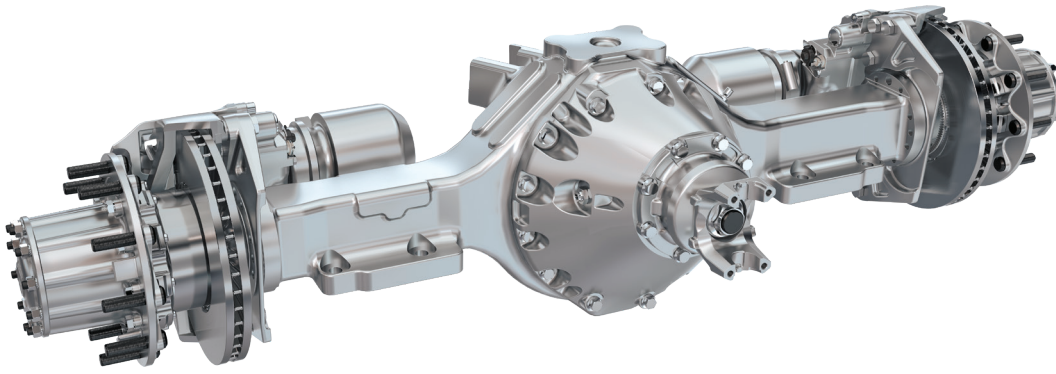

## SINGLE REAR AXLE SPECIFICATIONS

| Ratings*                                | Axle model | Standard ratios  | Ring gear size (ref.) | Axle shaft spline size      | Axle shaft diameter               | Housing box size                                 | Wall thickness at spring seat                    | Wheel-end series |
|---|------------|--|-----------------------|-----------------------------|-----------------------------------|--|--|------------------|
| <b>21,000 lbs</b><br><b>(9,534 kg)</b>  | MS-21-14X  | 2.64, 3.08, 3.25, 3.36, 3.42, 3.55, 3.70, 3.90, 4.11, 4.33, 4.63, 4.88, 5.13, 5.29, 5.57, 5.86, 6.14, 6.43, 6.83, 7.17 | 15.31 in (389 mm)     | 2.1 in (53 mm)<br>41 teeth  | 1.88 in (48 mm)<br>2 in (51 mm)   |  | 0.43 in (11 mm)<br>0.56 in (14 mm)<br>wide track |                  |
|   | RS-21-160  |  |                       |                             |                                   |  | 0.43 in (11 mm)<br>0.63 in (16 mm)<br>wide track |                  |
| <b>23,000 lbs</b><br><b>(10,433 kg)</b> | RS-23-160  | 2.50, 2.67, 2.80, 2.93, 3.07, 3.21, 3.42, 3.58, 3.73, 3.91, 4.10, 4.30, 4.56, 4.89, 5.38, 5.63, 6.14, 6.43, 6.83, 7.17 | 18 in (457 mm)        | 2.35 in (60 mm)<br>46 teeth | 2.25 in (57 mm)                   | 5.25 in x 4.62 in (134 mm x 117 mm)              | 0.43 in (11 mm)<br>0.63 in (16 mm)<br>wide track | R                |
|   | RS-23-161  |  |                       |                             |                                   |  | 0.50 in (13 mm)                                  |                  |
|   | RS-23-186  | 4.30, 4.56, 4.89, 5.13, 5.38, 5.63, 5.86, 6.14, 6.83, 7.17, 7.83   | 19.62 in (498 mm)     |                             |                                   |  | 0.63 in (16 mm)                                  |                  |
| <b>24,000 lbs</b><br><b>(10,886 kg)</b> | RS-24-160  | 2.50, 2.67, 2.80, 2.93, 3.07, 3.21, 3.42, 3.58, 3.73, 3.91, 4.10, 4.30, 4.56, 4.89, 5.38, 5.63, 6.14, 6.43, 6.83, 7.17 | 18 in (457 mm)        | 2.35 in (60 mm)<br>46 teeth | 2.25 in (57 mm)                   | 5.5 in x 5.5 in (140 mm x 140 mm)                | 0.56 in (14.3 mm)                                | T                |
| <b>25,000 lbs</b><br><b>(11,350 kg)</b> | RS-25-160  |  |                       |                             |                                   |  | 0.71 in (18 mm)                                  | MTOR             |
| <b>26,000 lbs</b><br><b>(11,793 kg)</b> | RS-26-185  | 4.30, 4.56, 4.89, 5.13, 5.38, 5.63, 5.86, 6.14, 6.83, 7.17, 7.83   | 19.62 in (498 mm)     |                             |                                   |  |  |                  |
| <b>29,000 lbs</b><br><b>(13,000 kg)</b> | 79000**    | 4.56, 4.89, 5.38, 5.63, 6.14   | 19.68 in (500 mm)     |                             | Variable (cast housing)           | 0.56 in (14 mm)                                  |  |                  |
| <b>30,000 lbs</b><br><b>(13,620 kg)</b> | RS-30-185  | 3.42, 3.58, 3.73, 3.91, 4.10, 4.30, 4.56, 4.89, 5.38, 5.63, 6.14, 6.83, 7.17, 7.83                                     | 19.62 in (498 mm)     |                             | 5.5 in x 5.5 in (140 mm x 140 mm) | 0.56 in (14 mm)                                  |  |                  |
|   | RS-30-380  | 5.52, 6.07, 6.37, 6.75, 7.24, 7.83, 9.14, 10.12, 10.62   |                       |                             |                                   | 0.56 in (14 mm)                                  |  |                  |
| <b>35,000 lbs</b><br><b>(15,876 kg)</b> | RS-35-185  | 3.42, 3.58, 3.73, 4.30, 4.56, 4.89, 5.13, 5.38, 5.63, 5.86, 6.14   |                       |                             |                                   | 0.56 in (14 mm)<br>0.63 in (16 mm)<br>wide track |  |                  |

\* Refer to publication TP7824 for complete axle specification details. Higher load ratings may be granted for specific axles based upon application review and customer integration studies/approvals. Contact your sales representative for exact specifications for your application.

\*\* Bus and coach applications only.

# TANDEM AXLES

For many applications, nothing less than a tandem axle will suffice. Our tandems deliver the performance and the goods with legendary durability plus low maintenance and operating costs.

## FEATURES AND BENEFITS

- Robust inter-axle differential (IAD) provides torque capacity up to 2,050 pound-feet in certain applications; our latest pinion, differential and needle bearing design provides long life and excellent reliability
- Wide 2.64 – 7.17 vocation ratio range to match your application and specific engine manufacturer's recommendations
- DualTrac™ housing option repositions the loading on wheel bearings similar to dual tire configurations when used with 0-inch to 0.56-inch outset wheels
- High-torque gear design provides smooth and quiet operation, high-torque capacity and long component life
- Rugged, single-piece carrier design for precise gear alignment
- Central tire inflation system (CTIS) compatible
- Optional aluminum rear carrier (available for RT-40-145A family only) reduces weight to deliver additional payload capacity and greater fuel economy
- Broad range of gear ratios available to meet specific needs for improved fuel economy, greater torque or maximum traction
- Low maintenance tandem design extends range up to 500,000 miles between lube changes
- Anti-lock braking system (ABS) and automatic traction control (ATC) options are designed to provide greater braking control, shorter stopping distances and improved traction for both starting and higher-speed driveability
- Optional driver-controlled differential lock (DCDL) for enhanced traction and spin out protection in slippery conditions

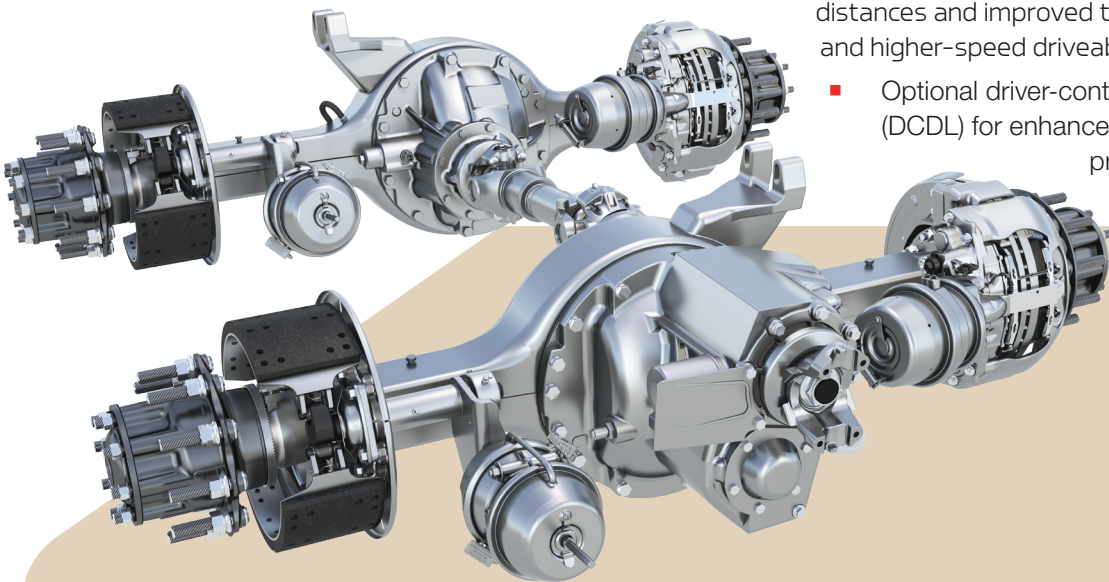

## TANDEM AXLE SPECIFICATIONS

| Ratings*                      | Axle model  | Standard ratios  | Ring gear size (ref.) | Axle shaft spline size    | Axle shaft diameter          | Housing box size  | Wall thickness at spring seat   | Wheel-end series |
|-------------------------------|-------------|--|-----------------------|---------------------------|------------------------------|---|---|------------------|
| <b>40,000 lbs (18,160 kg)</b> | MT-40-14X/P | 2.64, 3.08, 3.25, 3.36, 3.42, 3.55, 3.70, 3.90, 4.11, 4.33, 4.63, 4.88, 5.29, 5.86, 6.14, 6.43, 6.83, 7.17       | 15.31 in (389 mm)     | 2.1 in (53 mm) 41 teeth   | 1.88 in (48 mm) 2 in (51 mm) | 5.25 in x 4.52 in (134 mm x 117 mm)   | 0.37 in (9.5 mm) standard/DualTrac<br>0.43 in (11 mm) standard/DualTrac<br>0.5 in (13 mm) standard/DualTrac<br>0.56 in (14.3 mm) wide track | R                |
|                               | RT-40-145A  | 2.64, 2.79, 2.93, 3.07, 3.21, 3.42, 3.58, 3.73, 3.90, 4.11, 4.33, 4.63, 4.88, 5.29, 5.86, 6.14, 6.43, 6.83, 7.17 |                       |                           |                              |   | 0.37 in (9.5 mm) standard/DualTrac<br>0.43 in (11 mm) standard/DualTrac<br>0.56 in (14.3 mm) wide track                                     |                  |
|                               | RT-40-160   | 3.42, 3.58, 3.73, 3.91, 4.10, 4.30, 4.56, 4.89, 5.38, 5.63, 6.14, 6.43   | 18 in (457 mm)        | 2.35 in (60 mm) 46 Teeth  | 2.25 in (57 mm)              |   | 0.43 in (11 mm) 0.63 in (16 mm) wide track only; available as RT-46-164 series  |                  |
|                               | RT-40-160P  |  |                       |                           |                              |   |   |                  |
| <b>44,000 lbs (19,976 kg)</b> | MT-44-14X/P | 3.70, 3.90, 4.11, 4.13, 4.63, 4.88, 5.29, 5.86<br>Available on hypoid ratios only                                | 15.31 in (389 mm)     | 2.1 in (53.3 mm) 41 Teeth | 2 in (51 mm)                 | 0.5 in (13 mm) standard track<br>0.56 in (14 mm) wide track                   |   |                  |
| <b>46,000 lbs (20,884 kg)</b> | RT-46-160P  | 3.42, 3.58, 3.73, 3.91, 4.10, 4.30, 4.56, 4.89, 5.38, 5.63, 6.14, 6.43, 6.83, 7.17                               | 18 in (457.2 mm)      | 2.35 in (60 mm) 46 Teeth  | 2.25 in (57 mm)              | 0.5 in (13 mm) 0.63 in (16 mm) wide track only; available as RT-46-164 series |   |                  |
|                               | RT-46-164P  |  |                       |                           |                              |   |   |                  |
| <b>50,000 lbs (22,700 kg)</b> | RT-50-160   | 3.42, 3.58, 3.73, 3.91, 4.10, 4.30, 4.56, 4.89, 5.38, 5.63, 6.14, 6.43, 6.83, 7.17                               | 18 in (457.2 mm)      | 2.35 in (60 mm) 46 Teeth  | 2.25 in (57 mm)              | 0.63 in (16 mm)   |   |                  |
|                               | RT-50-160P  |  |                       |                           |                              |   |   |                  |
| <b>52,000 lbs (23,608 kg)</b> | RT-52-185   | 4.30, 4.56, 4.89, 5.38, 6.14, 6.83, 7.17   | 19.62 in (498 mm)     |                           |                              | 5.5 in x 5.5 in (140 mm x 140 mm)   | 0.56 in (14 mm)   | T                |
| <b>58,000 lbs (26,332 kg)</b> | RT-58-185   | 3.73, 4.10, 4.30, 4.56, 4.89, 5.38, 6.14, 6.83, 7.17   |                       |                           |                              |   | 0.56 in (14 mm) 0.63 in (16 mm) wide track  | U                |

\* Refer to publication TP7824 for complete axle specification details. Higher load ratings may be granted for specific axles based upon application review and customer integration studies/approvals. Contact your sales representative for exact specifications for your application.

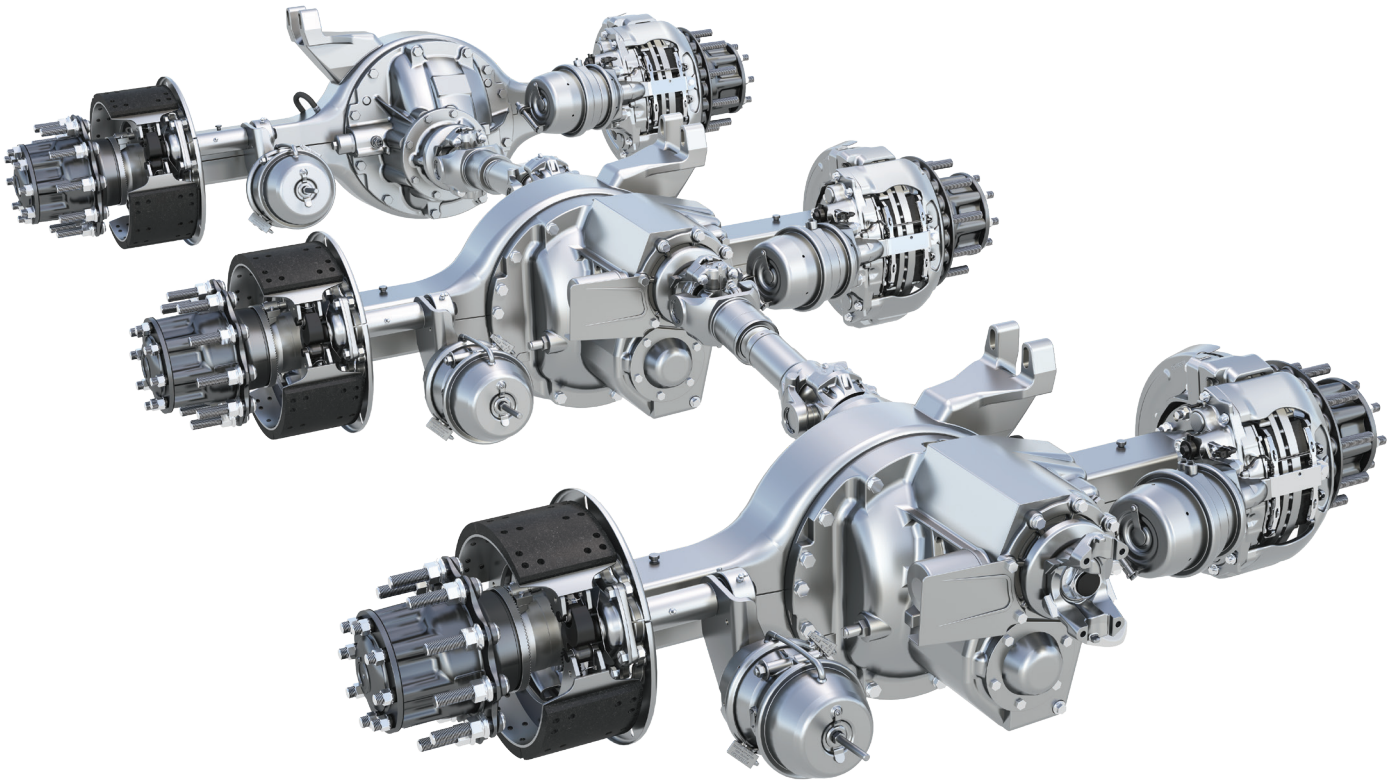

# TRIDEM AXLES

Our tridem axles are designed for the harshest environments. They are ideal for applications requiring more tractive effort than can be provided by a conventional tandem axle.

## FEATURES AND BENEFITS

- Three driving axles for even distribution of the available tractive effort to the ground; all three axles are assumed equally loaded at all times
- Hypoid-generoid gearing (18 inches or 19.6 inches) provides long life, exceptional strength and quiet operation
- Precision-forged differential gears for more durability and strength
- Optional driver-controlled differential lock (DCDL) for enhanced traction and spin out protection
- Optional pressurized, filtered tube system virtually eliminates the potential for spin out damage

## TRIDEM AXLE SPECIFICATIONS

| Ratings*                          | Axle model | Standard ratios  | Ring gear size (ref.)               | Axle shaft spline size      | Axle shaft diameter | Housing box size  | Wall thickness at spring seat      | Wheel-end series |
|-----------------------------------|------------|--|-------------------------------------|-----------------------------|---------------------|---|------------------------------------|------------------|
| <b>69,000 lbs<br/>(31,326 kg)</b> | RZ-166     | 3.42, 3.58, 3.73, 3.91, 4.10, 4.30, 4.56, 4.89, 5.38, 5.63, 6.14, 6.43, 6.83, 7.17 | Axle 1, 2 and 3<br>18 in (457 mm)   | 2.35 in (60 mm)<br>46 Teeth | 2.25 in (57.2 mm)   | Axle 1, 2 and 3<br>5.25 in x 4.62 in<br>(134 mm x 117 mm) | Axle 1, 2 and 3<br>0.62 in (16 mm) | R                |
| <b>77,000 lbs<br/>(34,958 kg)</b> | RZ-188     | 3.73, 3.91, 4.10, 4.30, 4.56, 4.89, 5.38, 6.14, 6.83, 7.17                         | Axle 1, 2 and 3<br>19.6 in (498 mm) |                             |                     | Axle 1, 2 and 3<br>5.5 in x 5.5 in<br>(140 mm x 140 mm)   | Axle 1, 2 and 3<br>0.56 in (14 mm) | T                |

\* Refer to publication TP7824 for complete axle specification details. Higher load ratings may be granted for specific axles based upon application review and customer integration studies/approvals. Contact your sales representative for exact specifications for your application.

# PROTEC™ INDEPENDENT FRONT SUSPENSION

The ProTec Independent Front Suspension (IFS) is based on the field-proven technology of the industry-leading ProTec series of independent suspensions and beam axles. Purpose-built for the most demanding applications and backed by our extensive heritage of delivering innovative on-highway, off-highway and specialty vehicle solutions for more than a century, the ProTec IFS is the answer to the suspension requirements of the motor coach industry.

## FEATURES AND BENEFITS

- Proven independent suspension technology – The ProTec brand has been synonymous with quality and durability for high-mobility vehicles for over 20 years and the ProTec Independent Front Suspension (IFS) leverages this expertise in design and performance
- Built for compatibility – Fully integrated suspension and steering system designed to be a “drop-in” replacement to existing suspensions
- Application specific tuning – High performance dampers from commercial suppliers with various tuning methods for steering, springs, anti-roll bars and dampers, per application demands
- Modern steering geometry – Stiff, low compliance suspension and steering pivots improve driver control and stability for safe and confident handling
- Ease of use and service – Maintenance-free suspension pivots
- Extensive testing and validation – Simulation and optimization through finite element analysis (FEA) and kinematic analysis including full- and sub-system durability and reliability testing in our test labs
- Manufacturing excellence – Cast suspension components and precision-fabricated subframe provides durability while enhanced suspension kinematics improves ride and handling
- Unmatched technical support – All products are backed by OnTrac™ – our award-winning service team – available to assist customers before, during and after the sale

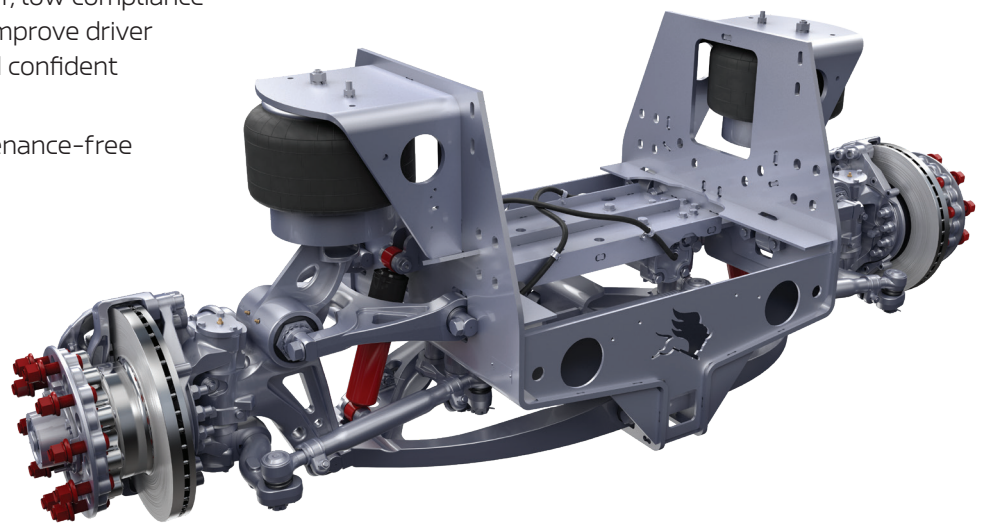

## PROTEC IFS MIS-20E SPECIFICATIONS

| Gross axle weight rating (GAWR) | Configuration   | Wheel mount                              | Brakes | Springs                              | Shocks                         | Total vertical wheel travel | Hub flange to flange | Track width        | Max. steering angle | Camber | King pin inclination |
|---------------------------------|---|--|--------|--------------------------------------|--------------------------------|-----------------------------|----------------------|--------------------|---------------------|--------|----------------------|
| 20,000 lbs (9,072 kg)           | Double wishbone with non-compliant control arm bushings and inverted dual steering box layout | Hub-piloted 10-stud 11.25 in (286 mm) BC | EX+™ L | Air springs with integrated bump aid | High-capacity twin-tube shocks | 6.5 in (165 mm)             | 96.6 in (2,454 mm)   | 85.6 in (2,174 mm) | 55°                 | 0°     | 8.5°                 |

Note: Options may not be available on every configuration. Rating, ratios and main dimensions are subject to engineering approval.

# DRIVELINES

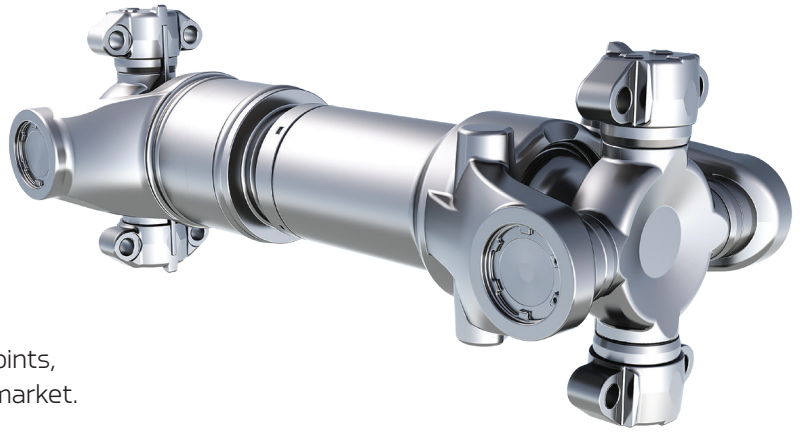

## RELIABLE, LOW-MAINTENANCE DRIVELINES

We offer a complete line of industry-leading drivelines and individual components, including u-joints, center bearings, yokes and more for the specialty market.

## PERMALUBE™ RPL SERIES DRIVELINES

The Permalube RPL Series drivelines are the first in North America to be permanently lubricated and sealed for life to reduce costs associated with downtime for greasing and maintenance. RPL Series drivelines deliver the highest torque capacity for demanding off-highway applications and the nylon thrust washers eliminate metal-to-metal contact to prevent wear. The triple lip seals along with the protective steel guard provide the ultimate protection against contaminants for extended u-joint life.

For more information or to review model details and specifications, see the Permalube RPL Series Drivelines insert on Literature On Demand.

# BRAKES

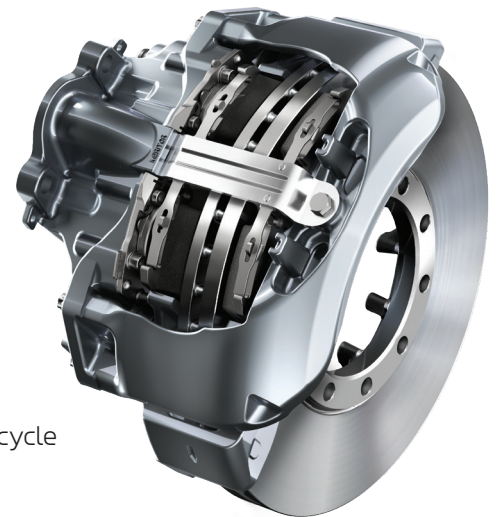

## PREMIUM STOPPING PERFORMANCE

We understand that premium stopping performance is a must for specialty markets, which often operate at maximum payloads. That's why we've developed high-performance options that enhance the performance and lifecycle of the vehicles.

## CAST+ P SERIES CAM BRAKES

For vocational and service vehicles, Cast+ cam brakes offer high durability and reliability with a single-piece, cast shoe and thick, extended-life brake linings that help resist heat related wear in heavy-duty coach and off-road applications. Available in 16.5 inches by 6 inches or 16.5 inches by 8.625 inches P-Series.

## FOUNDATION BRAKING AT ITS BEST

As an industry brake leader, you can expect an array of braking options to choose what's best suited for your application. Our Q+ drum brake is an industry standard, offering premium stopping performance and minimal maintenance. For high resistance to fade – in even the most severe conditions – the EX+ air disc brake offers proven reliability in frequent-stop applications, including on-highway, linehaul and vocational refuse.

Whatever brake package best suits your axle and application, trust that our heritage of braking performance in the fire and rescue industry ensures that it's engineered for performance in demanding specialty work environments.



## SPECIALTY PRODUCTS DEMAND SPECIAL SERVICE

### WE'RE BEHIND YOU ALL THE WAY

You can count on DriveForce™ to keep moving your operation forward. With more than 100 field representatives in North America, DriveForce provides an extensive support network in the commercial vehicle industry. To locate your DriveForce representative, visit

<https://www.cummins.com/components/drivetrain-systems/customer-support>

### YOUR TRAINING RESOURCE

BullPen is a convenient web portal designed for dealers, fleets and service garages to access product information and receive online training at one central location. The BullPen provides access to more than 1,000 items including product presentations, sales literature, product videos and photos, service bulletins and parts books. For more information or to register for courses, visit [meritorbullpen.com](http://meritorbullpen.com).

### WARRANTY HELP IS A PHONE CALL AWAY

Every specialty product is backed by strong support from DriveForce plus the OnTrac™ technical support center. The OnTrac team is equipped with expert service professionals who will help you with troubleshooting and handling warranty issues, such as validating coverage, opening a new claim, following-up on an ongoing claim or closing an existing claim.

Call **866-668-7221 (OnTrac1)** for assistance with diagnostics, repair and warranty solutions. OnTrac offers extended hours for your convenience—the team is standing by 8 a.m. – 8 p.m. EST Monday – Friday and 9 a.m. – 6 p.m. Saturday.

### UNSURPASSED CUSTOMER SUPPORT

Every specialty product is backed by strong support from DriveForce plus the OnTrac™ technical support center. For more information, call **866-668-7221 (OnTrac1)** or visit [cummins.com](http://cummins.com) today.



Cummins Inc.  
Box 3005  
Columbus, IN 47202-3005  
U.S.A.

[cummins.com](http://cummins.com)

SP-18126  
Bulletin 6459657 Produced in U.S.A. Rev. 10/25  
©2025 Cummins Inc.